



FAN MÜHENDİSLİĞİ

USER MANUAL

AXIAL
BIDIRECTIONAL
JET FAN

AIR-J-U SERIES



TABLE OF CONTENTS

LIST OF FIGURES.....	3
LIST OF TABLES.....	3
COMPANY INFORMATION	4
WARRANTY and SERVICE	5
WARRANTY TERMS	6
SPECIAL WARRANTY TERMS.....	8
USER'S RESPONSIBILITIES AND WARRANTY.....	9
PRODUCT INFORMATION.....	10
PRODUCT DESCRIPTION.....	10
AİRONN AIR-J-U SERIES FAN LABEL.....	11
AREA OF USE	12
PACKAGE CONTENTS.....	12
GENERAL NOTES ABOUT THE MACHINE	13
ABBREVIATIONS	14
OVERALL DIMENSIONS AND TECHNICAL SPECIFICATIONS	15
GENERAL SAFETY INSTRUCTIONS.....	17
WARNING LABELS ON THE MACHINE	17
DURING TRANSPORTATION AND SHIPPING.....	18
DURING INSTALLATION AND PLACEMENT.....	21
DURING OPERATION	22
DURING MAINTENANCE.....	23
DURING SCRAPPING.....	25
PRODUCT STORAGE	26

ASSEMBLY INSTRUCTIONS	28
ELECTRICAL CONNECTION INSTRUCTIONS	30
ELECTRICAL CONNECTION DIAGRAM	33
PRODUCT USE	34
1-MANUAL OPERATION	34
2-AUTOMATED USE.....	34
CARE INFORMATION	35
PERIODIC MAINTENANCE.....	35
POSSIBLE MALFUNCTIONS AND ELIMINATION.....	37
WARRANTY CERTIFICATE	39

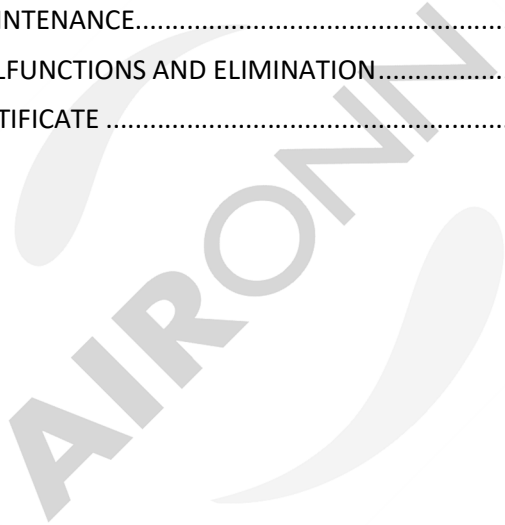

LIST OF FIGURES

NO	FIGURE	DESCRIPTION	PAGE NO
1	Figure - 1	Axial Bidirectional Jet Fan Series	10
2	Figure - 2	Axial Bidirectional Jet Fan Series Label Sample	11
3	Figure - 3	Axial Bidirectional Jet Fan Series Overall Dimensions	15
4	Figure - 4	Warning labels on the machine	17
5	Figure - 5	Axial Bidirectional Jet Fan Connection Type	29
6	Figure - 6	Δ Connection	32
7	Figure - 7	Y Connection	32
8	Figure - 8	Y/ Δ Connection	32
9	Figure - 9	Terminal Connection Diagram for Double Speed Dahlander Wound Motor	32

LIST OF TABLES

NO	TABLE	DESCRIPTION	PAGE NO
1	Table - 1	Axial Bidirectional Jet Fan Series (Single Speed) Technical Specifications	16
2	Table - 2	Axial Bidirectional Jet Fan Series (Double Speed) Technical Specifications	16
3	Table - 3	Possible mechanical failures and their elimination	37
4	Table - 4	Possible electrical faults and their elimination	38

COMPANY INFORMATION

AIRONN HAVALANDIRMA VE KLİMA SİSTEMLERİ SAN. DIŞ TİC. LTD. ŞTİ
CENTRAL OFFICE : TATLISU MAH. ŞENOL GÜNEŞ BULVARI MİRA TOWER
KAT: 3 D: 16 ŞERİFALİ/ATAŞEHİR/İSTANBUL
: KARATEPE MAH. CUMHURİYET CAD. MERA SOK. NO:13
FACTORY KARTEPE/KOCAELİ
TEL / FAX : +90 216 594 5696 / +90 216 594 5717
WEB : www.aironn.com.tr
E-MAIL : info@aironn.com.tr / fabrika@aironn.com.tr



WARRANTY and SERVICE

We kindly ask you to follow the recommendations set out below;

1. When you purchase your product, do not forget to have the Warranty Certificate approved by your Authorized Dealer.
2. Follow the instructions in the user manual when using your product.
This warranty given by AIRONN Ventilaiton does not cover the elimination of malfunctions caused by the use of the product outside the instructions specified in the user manual. The following conditions are also excluded from the warranty:
 1. Damages and malfunctions occurring during transportation, loading and unloading after the delivery of the product to the customer,
 2. Damages and malfunctions caused by natural disasters such as fire, earthquake, lightning strike, etc,
 3. Faulty electrical installation, low or excessive voltage, damage and malfunctions that may occur if the product is used at a voltage different from the voltage on the label,
 4. Damages and malfunctions caused by user errors.
3. The repair of the above-mentioned damages and malfunctions is made by setting a fee according to the extent of the damage and malfunction. Transportation and installation of the product to the place where it will be used are excluded from the product price.
4. It is the responsibility of the seller, dealer, agent or representative from whom the consumer has purchased the product to approve and deliver this warranty certificate to the customer.
5. In case of any dispute during the warranty period of the product, the user must keep the invoice or a legible photocopy of it together with the Warranty Certificate.
6. The Warranty Certificate of the product is invalid if the Warranty Certificate of the product is modified, the original serial number on the product is removed or changed.

WARRANTY TERMS

- The warranty period is 24 months from the date of delivery of the product.
- All parts on the product are under warranty under the assurance of AIRONN Ventilation.
- In the event of a malfunction, the repair of the product cannot exceed 20 working days and the repair period is added to the warranty period. The repair period starts when the user notifies the service station or, if there is no service station, the seller, dealer, agent, representative, importer or manufacturer of the product. Fault notification can be made by the consumer via telephone, e-mail, fax, registered letter with return receipt, etc. However, in the event of a dispute, the burden of proof lies with the consumer. If the malfunction of the product is not resolved within 10 business days, the manufacturer or importer company must make another product with similar features available to the consumer until the repair of the product is completed.
- In the event that the product suffers a malfunction caused by material, workmanship and assembly defects within the warranty period, it will be repaired without any labor cost, replacement part fee or any other charge.
- The elimination of malfunctions caused by the use of the product outside the instructions specified in the user manual is not covered by the warranty.
- For any problem that may arise regarding the Warranty Certificate, the General Directorate of Consumer Protection and Market Surveillance of the Ministry of Customs and Trade can be contacted.
- Consumers can file their complaints and objections to consumer courts and consumer arbitration committees.
- The product despite the consumer's right to repair;
 - From the moment of delivery to the consumer, provided that it is within the specified warranty period, at least 4 (four)

times within one year or 6 (six) times within the warranty period specified by the manufacturer or importer, and in case of failure to benefit from the goods caused by these failures,

- If the maximum time specified for repair is exceeded,
- In the event that it is determined that it is not possible to repair the malfunction with the report to be issued by the service station of the company, or in the absence of a service station, by any of its dealer, agency, representative, importer or manufacturer, respectively,

The consumer may request free replacement of the product, a refund or a discount on the sales price at the rate of defect.

- If the product is found to be defective, the consumer;
 - I. Withdrawal from the contract by declaring that you will return the product sold,
 - II. Retaining the sold product and asking for a discount on the sale price in proportion to the defect,
 - III. To demand free repair of the product sold at the seller's expense where the defect of the product does not require an excessive expense,
 - IV. If possible, to demand the replacement of the sold product with a defect-free equivalent,It may exercise only one of its optional rights. The seller is obliged to fulfill this request preferred by the consumer.

SPECIAL WARRANTY TERMS

1. Our company is not responsible for any damage that may occur during transportation and assembly by the customer.
2. Any malfunctions that may occur during the warranty period shall only be repaired by our service personnel or by service personnel who have received the necessary training and authorized by us. The warranty is void if other persons interfere with the machine without our written agreement.
3. The warranty given by our company is valid if the machine is used as described in this user manual, otherwise the warranty is void.
4. If the warranty certificate is falsified, the original serial number on the machine is removed or defaced, this warranty shall be void.
5. The warranty given is valid provided that the obligations and responsibilities of the customer written in this document, user manual and catalog are fully fulfilled.

USER'S RESPONSIBILITIES AND WARRANTY

AIRONN cannot be held responsible in any way for the following except as included in this user manual.

- Any use not permitted by laws and norms
- The area and structure where the machine will be used is inappropriate and unfavorable
- Failure to comply with or misuse the subjects specified in the manual
- Using electricity that is not suitable for the specified electrical installation
- Any modification not performed by authorized persons
- Using the machine beyond its performance
- Lack of necessary maintenance
- Use of the machine without trained personnel
- Use of non-original and non-manufacturer-approved spare parts



IT IS FORBIDDEN TO MAKE ANY MODIFICATIONS ON THE MACHINE !!!

PRODUCT INFORMATION

PRODUCT DESCRIPTION

Aironn Axial Bidirectional Jet Fan series fans have 300 °C-2 hours and 400 °C-2 hours certificates in accordance with EN 12101-3. The series with 290 mm - 400 mm diameter range can operate at the same performance in both blowing directions thanks to its reversible blade structure. The performance of the Axial Bidirectional Jet Fan series has been tested in accordance with the AMCA 250-12 standard.



Figure - 1: Axial Bidirectional Jet Fan Series

Fan Housing

The body of the fans is made of high quality galvanized steel. Adjustable guide vanes in both air throw directions are standard on the body of the jet fans.

Blades

Blades with aerodynamic structure are manufactured from ETIAL 171 material by injection molding method. Statically and dynamically balanced according to ISO 1940/1-2003.

Motor

IP 55 motors with H insulation class are available with single speed or double speed options. If desired, single-speed motors are suitable for inverter use. Thanks to the slide motor cradle, it provides ease of maintenance in operation.

Electricity

IP 55 electrical connection box in galvanized steel body is offered as standard.

Accessories

Maintenance Switch

AİRONN AIR-J-U SERIES FAN LABEL

	AIRONN HAVALANDIRMA VE KLİMA SİSTEMLERİ SAN. DIŞ TİC. LTD. ŞTİ.			
	Karatepe Mah. Cumhuriyet Cad. Mera Sok. No:13 Kartepe / Kocaeli Tel:0 216 594 56 96 Fax:0 216 594 57 17 www.aironn.com.tr - info@aironn.com.tr			
SİPARİŞ NO ORDER NO		İTKİ-(N) THRUST		
SERİ NO SERIAL NO				
CİHAZ KODU ITEM CODE	A I R - J - U	MOTOR kW		
		DEVİR/SPEED rpm		
CİHAZ MODELİ MODEL NO	JET FAN - DOUBLE DIRECTION	NOMİNAL AKIM RATED CURRENT		
*** TESTED Made in Turkey	Applus®	TSEK TSE-K 453	CE	OK 2018

Figure - 2: Axial Bidirectional Jet Fan Series Label Sample

AREA OF USE

AIR-J-U Series Axial Bidirectional Jet Fans are used in 2 situations: daily ventilation and emergency (fire) ventilation. In case of fire, jet fans are used to carry the smoke generated at the source of the fire out of the parking lot or warehouse and to help evacuate the people inside during this time.



THE INTENDED USE OF THE MACHINE IS CLEARLY STATED IN THIS MANUAL. IT IS STRICTLY FORBIDDEN TO USE THE MACHINE FOR OTHER THAN THESE PURPOSES !!!

AIRONN shall not be liable for any damages resulting from the use of the machine for other than its intended purpose.

The machine's operating capacity is limited to the channel dimensions on the label. AIRONN cannot be held responsible for any damages that may arise from using the machine beyond the specified capacity.

The machine is not suitable for operation in open weather conditions (rain, snow, wind, etc.). Any responsibility arising from the use of the machine in open areas belongs to the user.

AIR-J-U Series Axial Bi-Directional Jet Fans are designed for exhausting only contaminated air and fire smoke. AIRONN accepts no responsibility for any inconvenience that may occur if the machine is used for operations other than its function.

PACKAGE CONTENTS

- 1 Axial Bidirectional Jet Fan
- 1 user manual

GENERAL NOTES ABOUT THE MACHINE

All modifications to the machine by other than authorized personnel are prohibited. The manufacturer does not allow any misuse without authorization.

No danger, damage or any condition that may occur if the instructions in the user manual are not followed cannot be a binding reason for AIRONN HAVALANDIRMA VE KLİMA SİSTEMLERİ Ltd. The employer is obliged to provide all kinds of training and information to the user personnel in accordance with CE norms. **It is therefore obligatory that the user reads and understands this user manual before using the machine.**



MACHINE MAY ONLY BE USED BY AN AUTHORIZED OPERATOR!

The machine complies with the necessary safety precautions at all times if the instructions given in the MAINTENANCE INFORMATION section are followed. These instructions are provided as a precautionary measure against any safety risk to personnel using the machine. **Full capacity and efficient operation of the machine is ensured only if the instructions in this manual are followed.** This manual must be kept in an easily accessible place for as long as the machine is in use and any changes and warnings made by the manufacturer must be indicated on the manual. If the machine is sold to another user, the relevant manual must be handed over.

The manufacturer does not authorize the reproduction or copying of this manual for any reason whatsoever and all rights are reserved. All illustrations and drawings in the manual are intended as a guide. The manufacturer has the right to remove, delete and modify them.

The machine is delivered to the customer with a label with the machine identification information on it, which is nailed on the machine.

ABBREVIATIONS

AIR - XX - XXX

Fan Diameter (mm)

290, 315, 355, 400

Fan Type

JU - Axial Jet Fan

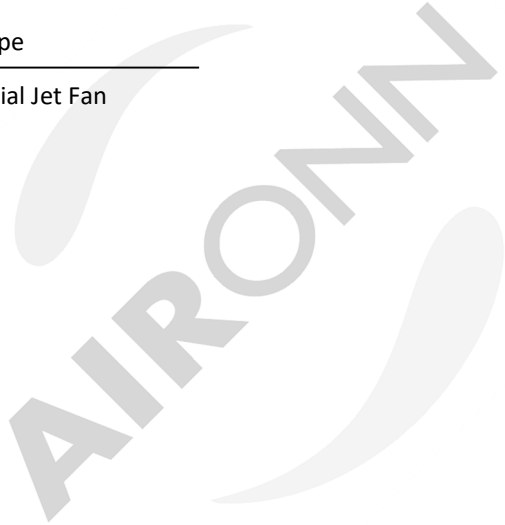

OVERALL DIMENSIONS AND TECHNICAL SPECIFICATIONS

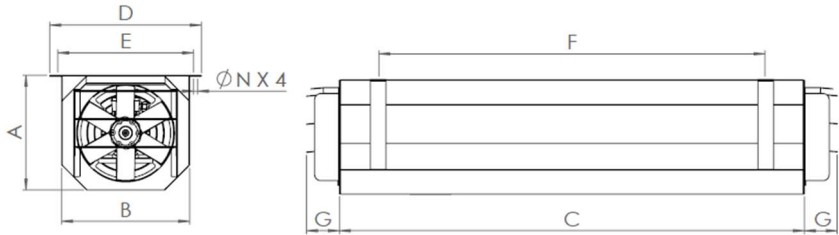

	A	B	C	D	E	G	ØN
290	310	378	1508	460	423	105	13
315	369	409	1500	489	451	105	13
355	409	429	1650	509	472	105	13
400	454	474	1880	554	516	105	13

Figure - 3: Axial Bidirectional Jet Fan Series Overall Dimensions

SINGLE CYCLE						
Type	Thrust (N)	Motor Power (kW)	Current Drawn (A)	Motor Speed (rpm)	Sound Level at 3m Distance (dBA)	Weight (kg)
AIR-J-U-290	30	0.75	1.57	2790	60 / 45	45
AIR-J-U-315	32	0.75	1.57	2790	60 / 45	50
AIR-J-U-355	55	1.5	3.01	2870	68 / 52	61
AIR-J-U-400	78	2.2	4.48	2840	72 / 55	80

Table - 1: Axial Bidirectional Jet Fan Series (Single Speed) Technical Specifications

DOUBLE CYCLE						
Type	Thrust (N)	Motor Power (kW)	Current Drawn (A)	Motor Speed (rpm)	Sound Level at 3m Distance (dBA)	Weight (kg)
AIR-J-U-290	30 / 8	0.8 / 0.2	1.91 / 0.6	2.820 / 1.400	60 / 45	45
AIR-J-U-315	30 / 8	0.8 / 0.2	1.91 / 0.6	2.820 / 1.400	60 / 45	50
AIR-J-U-355	55 / 14	1.5 / 0.37	3.54 / 1.25	2.900 / 1.435	68 / 52	61
AIR-J-U-400	78 / 19	2.2 / 0.8	4.63 / 1.54	2.845 / 1.420	72 / 55	80

Table - 2: Axial Bidirectional Jet Fan Series (Double Speed) Technical Specifications

GENERAL SAFETY INSTRUCTIONS

****This section contains safety instructions to be followed during transportation, installation, use, maintenance and scrapping of the machine.**

WARNING LABELS ON THE MACHINE



There's an electricity



Caution



Rotating Machine Warning



Danger of the hand getting stuck



Grounding



Standing Under Load

Figure - 4: Warning labels on the machine

**** These images and labels are for illustrative purposes. They may not exactly match the labels on the delivered machine.**

DURING TRANSPORTATION AND SHIPPING

To prevent any damage to your product during transportation;

- When packing the product, care has been taken to ensure that it is suitable for normal transportation conditions. It should always be transported in its original packaging to avoid possible damage and loss.
- Lifting and loading must only be carried out by authorized and qualified personnel.
- It should not be kept in rain or wet environments.
- The products must be placed in such a way that they remain completely immobile in the vehicle in which they will be transported in order to avoid a possible tipping or falling situation.
- The product must be kept in its own package in such a way that it is not exposed to any vibration, dust, corrosive or chemical substances until it reaches the place where it will be installed. Do not accept products that are not in the original package or that you find opened when you receive them.
- Appropriate lifts should be used to prevent damage to the product and the people carrying it during the transportation of products with high weight.
- All necessary precautions should be taken to prevent damage caused by imprudent, rapid lifting and lowering.

After the product has been unpacked;

- Please check the authenticity of the product you receive.
- Check that the product has not been damaged during transportation. If any missing or damaged part(s) are found, the transportation company and Aironn Logistics Department must be informed immediately verbally and in writing.
- When receiving the devices in the field, check from the delivery note that the parts shipped separately and unassembled from the device are shipped in a separate box. Keep these materials in a safe place.
- If any damage has occurred during transportation, take a photo of the damaged products and report it immediately to the authorized person of the **Aironn Logistics Department** and the **transportation company**.
- The product must not be lifted by the electrical cables or junction box. Avoid situations that may damage the blades during transportation.
- During transportation, personnel must wear a hard hat, gloves and steel-toed shoes.

Observe the following instructions during handling and transportation;

- 1- Ensure that the products are properly and securely packaged before placing them on the transportation vehicle.
- 2- Before lifting and transporting the fan or its accessories, observe the following points:
 - Total weight and center of gravity
 - Largest external dimensions
 - Location of lifting points
- 3- The lifting capacity of the vehicle used must be suitable for the weight of the fan and its accessories.
- 4- After all safety conditions are met, the lifting process should be started.
- 5- Never stand under or near the lifted load.
- 6- Do not use any protruding part of the device as a fulcrum for moving the device to the platform. To transport the device to the

- platform, only use the eyebolts specially fixed to the device for transportation or the large holes in the base pedestal.
- 7- The device must not be tilted or tipped over during transport or lifting.
 - 8- When removing the units from the truck with a forklift truck, it must be ensured that the load is evenly distributed on the forks of the forklift truck and that the forks do not hit the body and base frame of the device.
 - 9- If units are lifted from the truck by crane/crane, it must be ensured that the load is evenly distributed and no wire ropes should be used as lifting equipment. The parts of the device in contact with the rope must be protected.
 - 10- If any other lifting method is used, suitable lifting wedges must be placed under the device for lifting.
 - 11- Care must be taken and necessary precautions must be taken against violent impacts when lifting and placing the devices.
 - 12- Products must be transported by securing them to the transport vehicle.
 - 13- The unloading of the products from the vehicle must be carried out with the precision specified for the loading process.



IT IS FORBIDDEN TO PLACE ANY MATERIAL, TOOL OR LOAD ON THE PRODUCTS!

**** AIRONN cannot be held responsible for any adverse situation that may arise during the transportation of the product.**

DURING INSTALLATION AND PLACEMENT

Observe the following safety instructions during installation and positioning;

- Products must be transported to the place where they will be used within the enterprise with appropriate vehicles and in a safe manner.
- Products should be lowered to the floor slowly and in the correct position.
- During the installation process of the products, there must be no electricity in the system.
- Before the product connections are made, it must be ensured that the product is securely mounted on the wall, floor or in the places specified in the project.
- Fans are not ready for use when unpacked. The product must be operated after it is connected to its place as specified in the project and protection grilles are installed.
- Gloves must be worn during handling and installation.
- Before connecting the fan to the mains, check the housing for any damage. In addition, the fan impeller and suction section should be checked for foreign objects and removed if any.
- There should be no obstruction in the path of the air flow.
- The fans are supplied with three-phase 380 V / 50 Hz alternating current. The label must be checked before electrical energy is supplied.
- When the machine is taken out of service, it must be transported in accordance with the handling and transportation instructions.

DURING OPERATION

The machine described in the operating instructions has been manufactured according to appropriate principles, taking into account the law in force. The machine is equipped with the necessary technical solutions and devices to prevent any risk of accidents.

Observe the following safety instructions during operation:

- When the machine is in operation, personnel must not be present on the machine for any reason.
- The machine must only be used by a trained and authorized operator.
- Make sure that the protection grilles are connected before operation.
- Never touch the fan while it is running.



IT IS STRICTLY FORBIDDEN FOR THE PERSONNEL TO CLIMB ON THE MACHINE WHILE IT IS RUNNING!

***** These prohibitions may be partially violated by trained maintenance engineers who carry out investigations on the machine to detect faults and verify the causes of anomalies.***

DURING MAINTENANCE

During the periodic maintenance of the machine, signs with the warning phrase 'the machine is under maintenance' should be placed on the machine and in the area where maintenance is carried out. Maintenance must only be carried out by trained and competent personnel.

Observe the following safety instructions during maintenance:

- The machine must never be cleaned with water/pressurized water.
- Maintenance while the machine is in the air is dangerous and prohibited. Maintenance work should be carried out after the machine has been lowered to the ground.
- Before any maintenance work is carried out on the machine, the power must be disconnected from the main line.
- Maintenance should be carried out after the machine has come to a complete stop to avoid limb entrapment and crushing.
- Hand tools to be used during maintenance must be robust and safe, and defective or damaged equipment must not be used.
- When working with power tools (grinders, drills, etc.), personal protective equipment must be used.
- During electrical maintenance, power cables carrying energy must be replaced or repaired in such a way that they do not pose a danger to life safety.
- The work area to be maintained must be brightly lit to prevent any work accidents and to facilitate the work of the maintenance personnel.
- If there are flammable explosive materials around the maintenance area, they must be removed.



THE MACHINE MUST BE COMPLETELY DISCONNECTED FROM THE MAINS BEFORE STARTING MAINTENANCE !



NEVER PERFORM MAINTENANCE OR REPAIR WORK WHILE THE MACHINE IS RUNNING!

**** During routine inspection and maintenance of some parts of the machine, it may be necessary to keep the machine running. In this case, the machine must be switched off if the engineer, maintenance person or technician leaves the machine.**

DURING SCRAPPING

All parts of the machine are made from recyclable materials. All parts can thus be reused as raw material. No materials that may harm human health have been used in the production of the machine. At the end of its service life, the machine can be disassembled down to the smallest component and safely sent to the relevant recycling facilities.

Follow the instructions below during scrapping:

- Cutting and drilling tools to be used when the machine is disassembled into its components must be used in accordance with occupational safety rules.
- Personnel must take precautions against limb entrapment during disassembly.
- Disassembled and cut sharp-edged parts must be stored in such a position that they do not cause work accidents.
- The oil that will come out of machine components containing mineral oil, such as gearboxes, should be collected in a closed container in a way that does not harm human and environmental health and sent to the recycling facility.
- Scrap parts should be classified according to their type (iron, copper, aluminum, plastic, etc.) and sent to recycling facilities.
- No part of the machine is radioactive. Therefore, scrapped machine parts do not need to be stored in a special area.



PRODUCT STORAGE

Please follow the instructions below when storing the product after receipt;

- The product should be covered with a tarpaulin to ensure that it is protected against all weather conditions.
- The product should be kept in a closed area without being unpacked until the installation time.
- General rules must be observed when transporting the product from the storage site to the installation site.
- Care should be taken to ensure that the products transported to the construction site or assembly area are not exposed to weather conditions during storage and that there is no excessive dust and dirt in the environment.
- Products must not be stacked on top of each other. Products must not be stepped on or weighed down.
- Materials such as panels, profiles, etc. that may damage the product should not lean on the product.
- The product should not be placed in areas with heavy pedestrian/vehicle traffic.
- In the construction site storage area, the product must be placed on a chock.
- The product must be stored on the pallets delivered until the moment of assembly.

General warning;

The product is shipped from our factory wrapped in stretch film on the pallet or in a box. If water enters between the stretch film on the product delivered to the customer or stored at the assembly site, the product faces the danger of corrosion. Since the water remaining between the product and the stretch film will have a corrosive effect on the product with the effect of the sun, the stretch film should be removed immediately, the product should be dried in natural air conditions and stretched again. If the box gets wet, the product should be immediately removed from the box and dried in natural air conditions. If the dried product can be stored in a safe and clean environment, there is no need to stretch it again.

AIRONN

ASSEMBLY INSTRUCTIONS

Please pay attention to the following instructions during the installation of the products;

- Before starting installation, make sure that there is no visible damage to the motor supply cables and that the fan wheel rotates freely.
- The mounting position of the jet fans must be in accordance with the project. If there is a situation that is contrary to the project and/or inappropriate, the necessary information should be communicated to the project responsible. Solutions should be implemented on the ground as required by the situation.
- Jet fans can be mounted directly to the ceiling depending on the ceiling structure of the area where they will be mounted, or they can be mounted by hanging with a suspension system.
- The jet fan must be balanced, properly mounted, must not oscillate, must not cause any twisting of the body, and must not cause the jet fan blades to rub against the body.
- Jet fan mounting holes should be marked on the ceiling with a template and then drilled.
- Anchor bolts must be balanced and well tightened.
- It is recommended to mount the jet fan carrier rails to the ceiling with minimum M8 bolts.
- If there are various obstructions in the air throw direction of the jet fans, the jet fan should be lowered and/or displaced horizontally as appropriate. Any changes should be recorded in the project and communicated to the project responsible.
- Carrier lengths and diameters must be sufficient and the weight of the jet fan unit must be evenly distributed on the carrier.
- Care should be taken not to deform the jet fan body during installation.
- The jet fan must be accessible for maintenance work.

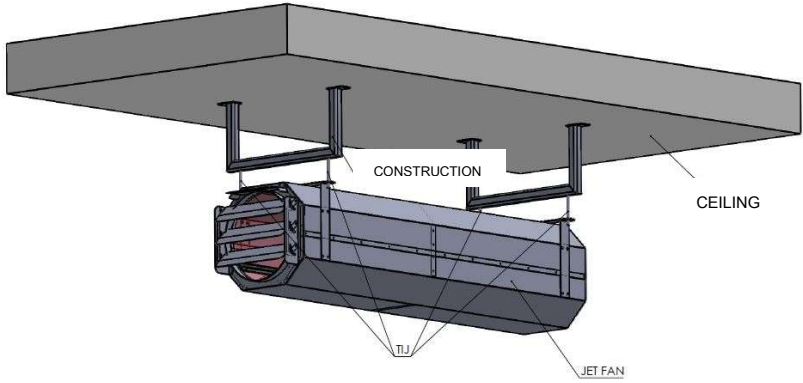

Figure - 5: Axial Bidirectional Jet Fan Connection Form



ELECTRICAL CONNECTION INSTRUCTIONS

- Before connecting the electrical cables, the existing power must be disconnected directly at the source.
- When mounting the apparatus, make sure that the mounting elements are capable of supporting the weight of the product and that all connections are made correctly.
- Hot-dip galvanized cable ducts should be used for electrical cables and cables should be laid in this duct in an orderly manner.
- Data cables must not be laid in the same duct with power cables. This is because power cables adversely affect the data transmitted through data cables.
- All cables must be systematically addressed and labeled with a durable material.
- Cables must be selected in accordance with the requirements specified in the fire regulations.
- The cables must be one piece from the supply point to the receiver and must not be spliced.
- The mechanical assembly of the panel modules and their assembly and installation on the floor must be made on a carrier base to be prepared.
- All kinds of supply, power, control and measurement cables up to the panel and jumper cables between the panel modules must be reliably and tightly connected to the panel.
- Inlet and end connections of fan motors cables to motor terminal boxes must be made by using flexible cable end connections, cable ferrule and cable lug.
- Motor terminal box covers must be closed and screws and union nuts must be tightened sufficiently.
- Before connecting the apparatus, check that the main power supply is switched off, even if the product is not in operation.

- The electrical connection information (frequency, voltage, power, etc.) indicated on the product must match the electrical connection information at the place of installation.
- For safety reasons, make sure that the grounding terminal on the terminal block is connected to the building earth line.
- Check that the overload relay and motor thermocouple are properly connected.
- In case of a possible problem, if the thermal circuit opens (when the product does not work), the system must be reset from the mains and reactivated.
- The product wiring must be as shown in the electrical wiring diagram.
- It must be connected to the fixed installation in accordance with the installation rules, together with a switch with contact disconnection on all poles.

*****Users are obliged to read the operation and maintenance manual carefully before using the fans.***

The first time you start your product;

- After disconnecting the power from the source, make sure that the electrical connections of the product are made safely and correctly.
- Carefully check that the safety equipment is properly connected.
- Make sure that the grounding connections are made correctly.
- Ensure that the electrical junction box and cable are correctly, securely and watertightly closed.
- Check that there are no obstructions in the air flow path and that the air outlet direction is in the direction indicated by the label on the housing.
- Make sure that the blades rotate in the correct direction.
- When the product is in operation, make sure that there is no knocking or rubbing noise or vibration caused by the rotation of the fan or extractor fan.
- The current and frequency values of the electrical supply must comply with the product labeling.

- In the unlikely event of a burnout of the electrical safety device, immediately disconnect the power supply from the mains. Check the entire installation again carefully before operating the product.
- If you encounter any problems, please contact the authorized persons.
****When the product is used continuously, in case of a possible failure, the type of failure must be determined. The technical service must be contacted to repair the malfunction.**
****It should never be intervened by persons other than technical service.**

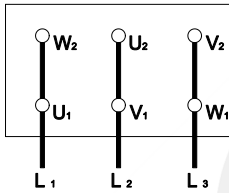

Figure - 6: Δ Connection

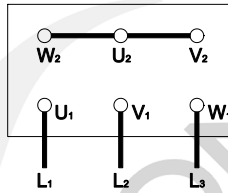

Figure - 7: Y Connection

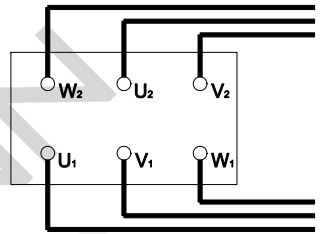

Figure - 8: Y/Δ Connection

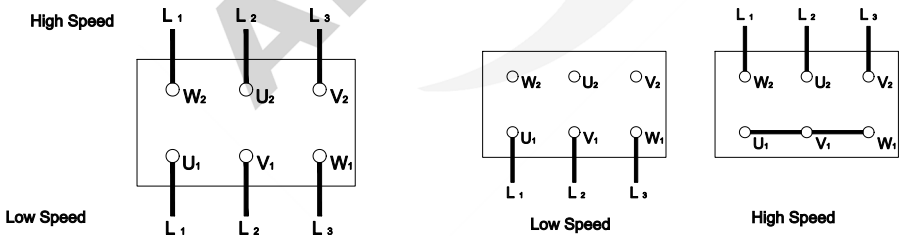
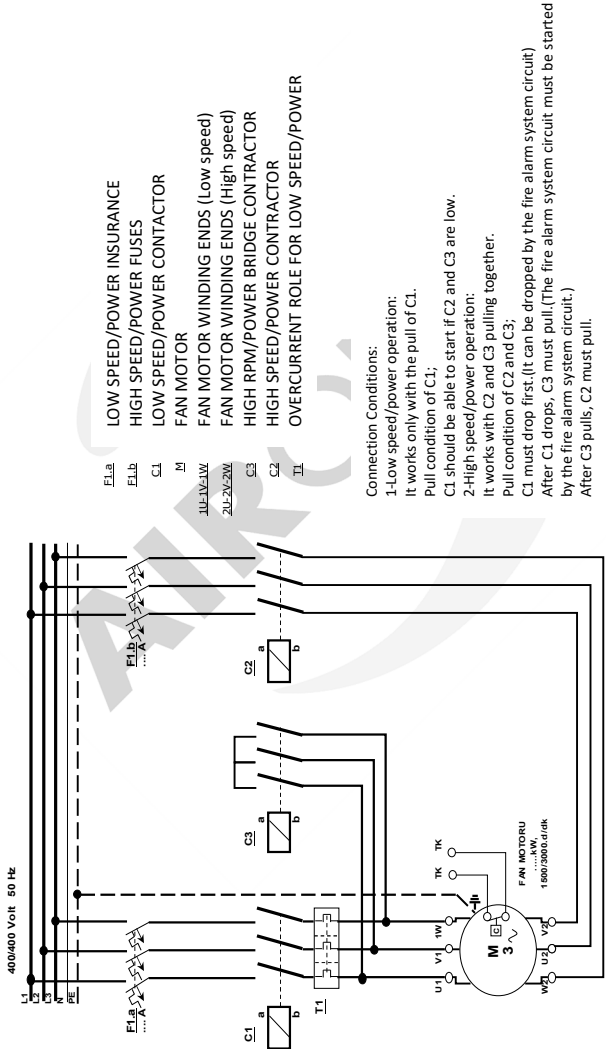

Figure - 9: Terminal Connection Diagram for Double Speed Dahlander Wound Motor

ELECTRICAL CONNECTION DIAGRAM



- LOW SPEED/POWER INSURANCE
- HIGH SPEED/POWER FUSES
- LOW SPEED/POWER CONTACTOR
- FAN MOTOR
- FAN MOTOR WINDING ENDS (Low speed)
- FAN MOTOR WINDING ENDS (High speed)
- HIGH RPM/POWER BRIDGE CONTACTOR
- HIGH SPEED/POWER CONTACTOR
- OVERCURRENT ROLE FOR LOW SPEED/POWER

Connection Conditions:
 1-Low speed/power operation:
 It works only with the pull of C1.
 Pull condition of C1;
 C1 should be able to start if C2 and C3 are low.
 2-High speed/power operation:
 It works with C2 and C3 pulling together.
 Pull condition of C2 and C3;
 C1 must drop first.(It can be dropped by the fire alarm system circuit)
 After C1 drops, C3 must pull.(The fire alarm system circuit must be started by the fire alarm system circuit.)
 After C3 pulls, C2 must pull.

PRODUCT USE

Axial Bidirectional Jet Fans have easy operation features. These usage features vary according to the wishes of the users. These are;

- 1- Manual operation
- 2- Automated use

1-MANUAL OPERATION

With manual use, it is possible to operate the product by operating it from the pako switch or fuse. Depending on the model, the product can be used easily and safely with the 0-1 switch logic by connecting a pako switch or fuse between the electrical energy and the junction box connection on the product.

2-AUTOMATED USE

It is possible to control the product with a PLC. This varies according to the project in which the user will use the product. The user can use the product efficiently by utilizing sensors, using a timer, using a wireless module, using an Internet of Things method, etc. If this application is preferred, it is recommended to add the "Manual operation" method as it will be needed during maintenance.

CARE INFORMATION

PERIODIC MAINTENANCE

Simple abnormalities during machine start-up may require simple maintenance interventions. These interventions are simple and can be performed by the operator. More complex interventions should be carried out by trained caregivers. Other complex interventions must be carried out by the manufacturer's technical service.

Depending on the year of operation and the working environment in which the machine is located, detailed visual and functional checks should be carried out by a specialized technician at least twice a year and the remaining life of the machine should be seen. The operator can take notes of the basic parameters at regular intervals so that the life of the machine can be properly determined. However, the maintenance technician should ask the operator about general service:

- When function abnormalities increase,
- When structural or mechanical failure may occur during maintenance,
- When will the machine reach its theoretical usage limit (or has it been 10 years since the first installation?).

All maintenance, warning abnormalities or breakdowns require a long period of use between the operator and the machine. This is a non-tradable feature of maintenance, which implies risks according to the model and machine production.

Traditionally, maintenance operators are more trained and skilled than other operators. Ultimately, of all installations and procedures, it is the safety of the person that matters most.

The following section describes the points to be considered during ordinary maintenance;

- Before starting maintenance, signs about maintenance, warning and prohibition of electrical connection should be placed.
- Before carrying out maintenance or cleaning, check that the mains supply is disconnected from the mains, even if the product has been switched off.
- Maintenance should not be performed while mechanical organs are moving.
- All electrical equipment should be checked regularly, connections should be reviewed and damaged or worn cables and equipment should be replaced.
- To avoid contamination or deposits on the blades and motor, maintenance must be carried out taking into account the operating conditions of the product. Failure to do so may shorten the service life of the product or cause a hazard.
- When cleaning the product, care must be taken not to disturb the balance in the blade and turbine.
- Check the tightness of bolts that may loosen during maintenance.
- Parts that are not in suitable condition must be replaced immediately.
- When cleaning the product, flammable and combustible cleaners should not be used, it should be cleaned by wiping with a damp cloth.
- The product must never come into direct contact with water or pressurized water.

*****AIRONN assumes no responsibility for malfunction and personnel safety due to any reason contrary to this manual.***

*****Electrical maintenance of the machine must be carried out regularly in daily, weekly, monthly and semi-annual periods by trained specialized personnel.***

POSSIBLE MALFUNCTIONS AND ELIMINATION

MECHANICAL FAILURES		
FAILURE	REASON	SOLUTION
Bolt and nut loosening	Exposure to vibration	Torque tightening of bolts and nuts using self-flanged bolts and nuts and vibration wedges
Breakage of the vibration chock heads, displacement of the machine if it is not fixed.	The vibration wedges are guaranteed for two years. If it works under poor conditions, it can break after about 3-4 years.	Replacing the vibration wedge heads
The wire cage rubbing against the fan.	Exposure to external factors such as planks hitting	Replacing the wireframe
Fan rubbing against the fan housing	Bending of the body as a result of applying force to the device from the top or side surfaces	Elimination of external factors Shortening of fan blades (turning) Removal of material stuck in the fan (such as nails, gloves, helmets)
Failure to reinstall the service hatch after removal	Exposure of the device to moisture and water	Closing the service hatch
Failure of parts such as loosening, breaking or breaking of the motor connection screw, rupture of the fan	Imbalance of the fan due to impact	Balance the fan and tighten the motor connection screw if it is loose. If the motor connection screw is broken, it must be replaced. If the fan is damaged, the fan blade or fan must be replaced.
Imbalance of the fan as a result of friction, compression and deformation. If the fan is running at high speed, the fan may warp, the impeller may break or the motor may burn out.	Removal of the fan protection cover	Regular inspection and maintenance of the fan and all mechanical parts
Friction, breakage and imbalance of the fan, burning of the motor. If the thermal relay does not close, the motor windings may be damaged. The motor base can slip if the connection is broken and the screw is caught in the fan.	Loosening and displacement of motor feet overbalance	Tightening or replacing screws or tightening or replacing bolts
Dislocation and shaking of the junction box	Dislocation due to external factors such as force and vibration	Regular inspection of fans and other mechanical components

Table - 3: Possible mechanical faults and their elimination

ELECTRICAL FAULTS		
FAILURE	REASON	SOLUTION
Voltage failure	Irregular electricity fails to provide the desired level of amplitude. Loosening of motor electrical terminal connections and irregularities in the panel and lines after the panel.	The operator regulates or phase distributes the power transmission line.
Failure to start the motor	Lack of star or triangular connections.	Making star triangle connections
Short circuit due to broken motor terminal connection screws	Exposure of the cable to mechanical stress from outside, corrosion due to loosening of bolts, use of poor quality materials	Check and connection must be made.
Short circuit	Exposure of the cable to external mechanical stress or over-tightening during installation	Replacing terminal connection screws
Failure of the thermal relay in the circuit in the current - voltage relationship	Reverse or loose connection of the cables between the motor and junction box, disconnection of the delta connection end of the motor to the outer junction box	Inspection and maintenance of fans
Motor disengagement due to overheating of the motor windings	Irregular rated current due to excessive outside temperature	Checking cables with a current meter
Cleavage and breakage of the plastic blades of the motor's rear cover cooling fan	Low voltage due to corrosion at cable ends	Replacing bearings eliminates harmful external influences
Cable burnout	Exposure to corrosion impact	Replacement of fan blades
Electricity leakage to the body during re-grounding during maintenance	Loosening of sleeves and leakage of liquid	Tightening or renewing sleeves
Motor winding burnout	Inadequate grounding	Checking that the grounding is connected and functional
Motor combustion and motor noise	Overcurrent	Replacing the motor
The motor does not start due to opening the control switch on the service hatch. (If the control switch is fitted) Malfunction of the control switch on the service hatch.	Irregular current irregular phase changes phase sequence	Control of the motor and correction of the current or phase by notifying the operation
Short circuit due to broken motor terminal connection screws	Corrosion arcing, rupture of end connections or impact exposure.	Check that the key in the service hatch and the motor are working.

Table - 4: Possible electrical faults and their elimination

WARRANTY CERTIFICATE

MANUFACTURER OR IMPORTER COMPANY	
TITLE	AIRONN HAVALANDIRMA ve KLİMA SİSTEMLERİ SAN. ve DIŞ TİC. LTD. STİ.
ADDRESS	Tatlısu Mah. Şenol Güneş Bulvarı Mira Tower Kat:3 D:16 Şerifali / İstanbul
TEL / FAX	(0216) 594 5696 / (0216) 594 5717
SIGNATURE AND STAMP OF THE AUTHORIZED PERSON OF THE COMPANY	
SELLER COMPANY	
TITLE	
ADDRESS	
TEL / FAX	
INVOICE DATE and NO	
SIGNATURE AND STAMP OF THE AUTHORIZED PERSON OF THE COMPANY	
PRODUCT'S	
TYPE	FAN
BRAND	AIRONN
MODEL	
BANDEROL and SERIAL NO.	
DELIVERY DATE and PLACE	
MAXIMUM REPAIR TIME	20 BUSINESS DAYS
WARRANTY TERM	2 YEARS
CUSTOMER'S	
NAME AND SURNAME	
ADDRESS	
PHONE NUMBER	